

## FITTING INSTRUCTION

| Clamp mark<br>in acc. with |     | Cables joining            |
|----------------------------|-----|---------------------------|
| ISO                        | PN  |                           |
| 1                          | L   | Left directional lights   |
| 2                          | +   | Rear fog lights           |
| 3                          | 31  | Ground                    |
| 4                          | R   | Right directional lights  |
| 5                          | 58R | Right side parking lights |
| 6                          | 54  | Stoplights                |
| 7                          | 58L | Left side parking lights  |

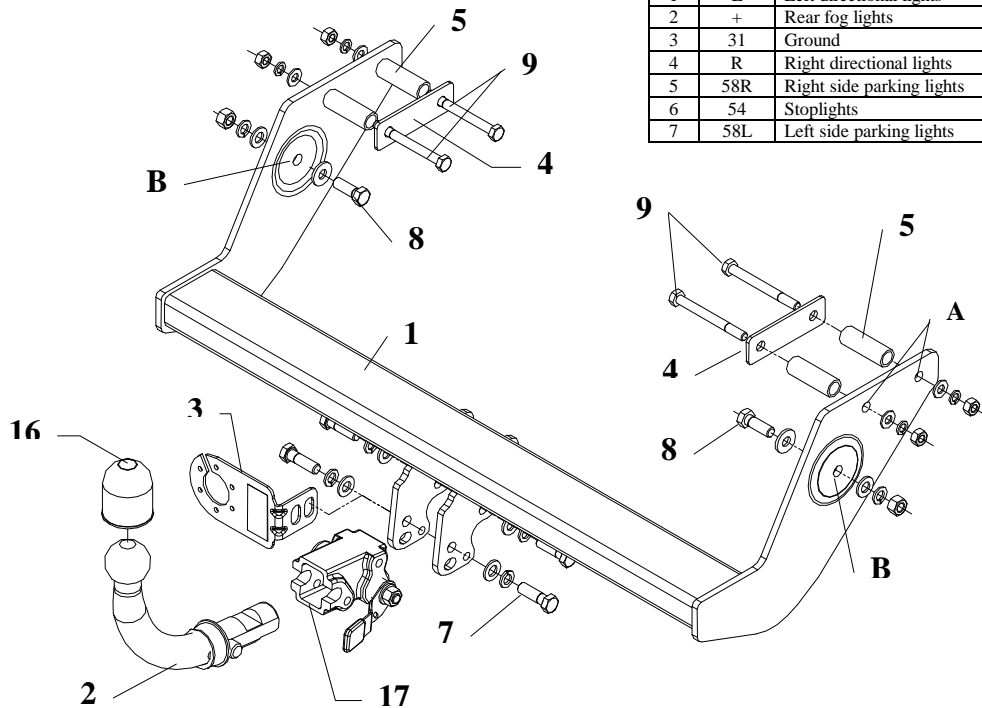

This towing hitch is designed to assembly in following cars:  
**MERCEDES Vaneo** produced since 2002, catalogue no. **D27A**  
 and is prepared to tow trailers max total weight **1200 kg** and max vertical  
 load **50 kg**.

### *From manufacturer*

Thank you for buying our product. Their reliability has been confirmed in many tests. Reliability of towing hitch depends also on correct assembly and right operation. For this reasons we kindly ask to read carefully this instruction and apply to hints.

*The towing hitch should be install in points described by a car producer.*

## Fitting instructions

1. Take the spare wheel out the bumper.
2. Unscrew the plastic covers at the bottom of the car.
3. Slide the distance sleeves L=62mm (pos. 5) to the original holes, then position the bar of towing hitch (pos. 1) (do it in such a way that holes pos. A cover holes of the distance sleeves) and fix it using M10x100mm (pos. 9).
4. Put the bolts M12x35mm (pos. 8) through the holes (pos. B) and fix it with the chassis member.
5. Fix body of the automat (pos. 17) and the socket plate (pos. 3) using bolts M12x25mm (pos. 7) from accessories. Place tow-ball (pos. 2) according to supplied instruction.
6. Tighten all nuts and bolts according to the torque shown in the table.
7. Connect the electric wires according to the instructions of the car.
8. Complete the paint cover of towing hitch (during the mounting paint cover could be destroyed).

Torque settings for nuts and bolts (8,8):

|             |       |             |        |
|-------------|-------|-------------|--------|
| <b>M 8</b>  | 25 Nm | <b>M 10</b> | 55 Nm  |
| <b>M 12</b> | 85 Nm | <b>M 14</b> | 135 Nm |











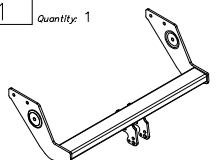







### NOTE

After install the towing hitch you should get adequate note in registration book (at authorised service station).The car should be equipped with:

- Indicators
- Tow mirrors

After 1000km check all bolts and nuts. The ball of towing hitch must be always kept clear and conserve with a grease.

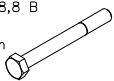
## Towing hitch accessories:

|   |   |   |   |
|---|---|---|---|
| Pos. 1<br>Name: Main bar<br>Quantity: 1<br>                        | Pos. 5<br>Name: Distance sleeve<br>Quantity: 4<br>Dim.: Ø21x2,35, L=62<br> | Pos. 10<br>Name: Nut 8 B<br>Quantity: 2<br>Dim.: M12<br>             | Pos. 15<br>Name: Spring washer<br>Quantity: 4<br>Dim.: Ø 10,2 mm<br> |
| Pos. 2<br>Name: Tow ball<br>Quantity: 1<br>                        | Pos. 6<br>Name: Washer<br>Quantity: 2<br>Dim.: Ø28xØ12x3mm<br>             | Pos. 11<br>Name: Nut 8 B<br>Quantity: 4<br>Dim.: M10<br>             | Pos. 16<br>Name: Ball cover<br>Quantity: 1<br>                       |
| Pos. 3<br>Name: Socket plate<br>Quantity: 1<br>                    | Pos. 7<br>Name: Bolt 8,8 B<br>Quantity: 4<br>Dim.: M12x25mm<br>            | Pos. 12<br>Name: Plain washer<br>Quantity: 6<br>Dim.: Ø 13 mm<br>    | Pos. 17<br>Name: Body of the automat<br>Quantity: 1<br>               |
| Pos. 4<br>Name: Flat washer<br>Quantity: 2<br>Dim.: 116x35x4mm<br> | Pos. 8<br>Name: Bolt 8,8 B<br>Quantity: 2<br>Dim.: M12x35mm<br>            | Pos. 13<br>Name: Plain washer<br>Quantity: 4<br>Dim.: Ø 10,5 mm<br>  | Pos. 18<br>Name: Body plug<br>Quantity: 1<br>                        |
|   | Pos. 9<br>Name: Bolt 8,8 B<br>Quantity: 4<br>Dim.: M10x100mm<br>           | Pos. 14<br>Name: Spring washer<br>Quantity: 6<br>Dim.: Ø 12,2 mm<br> |   |



**PPUH AUTO-HAK S.J.**

Produkcja Haków Holowniczych  
Henryk & Zbigniew Nejman  
76-200 SŁUPSK ul. Słoneczna 16K  
tel/fax (059) 8-414-414; 8-414-413  
E-mail: [office@autohak.com.pl](mailto:office@autohak.com.pl)  
[www.autohak.com.pl](http://www.autohak.com.pl)

## Towing hitch (without electrical set)

Class: **A50-X** Cat. no. **D27A**

Designed for:

Manufacturer: **MERCEDES**

Model: **VANEO**

produced since 2002

Technical data:

**D-value: 7,4 kN**

maximum trailer weight: **1200 kg**

maximum vertical cup load: **50 kg**

Approval number according to Directive 94/20/EC: **e20\*94/20\*0318\*00**

## Foreword

This towing hitch is designed according to rules of safety traffic regulations. The towing hitch is a safety component and must be installed only by qualified personnel. Any alteration or conversion to the towinh hitch is prohibited and would lead to cancellation of design certification. Remove insulating compound and underseal from vehicle (if present) in the area of the matting surfaces of the towing hitch.

The vehicle manufacturer's specifications regarding trailer load and max. vertical cup load are decisive for driving, and values for the towing hitch cannot be exceeded.

*D-value formula:*

$$\frac{\text{Max trailer weight [kg]} \times \text{Max vehicle weight [kg]}}{\text{Max trailer weight [kg]} + \text{Max vehicle weight [kg]}} \times \frac{9,81}{1000} = D \text{ [kN]}$$