

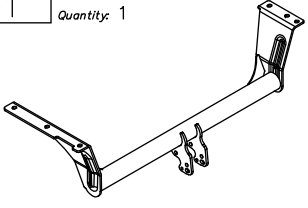









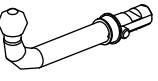

Towbar accessories:

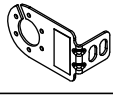
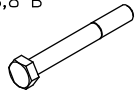
Pos. 1 Name: Main bar Quantity: 1 	Pos. 6 Name: Distance sleeve I Quantity: 2 Dim. : Ø17,2x2,35mm L=50mm 	Pos. 12 Name: Plain washer Quantity: 4 Dim. : Ø 13 mm 
	Pos. 7 Name: Distance sleeve II Quantity: 3 Dim. : Ø17,2x2,35mm L=60mm 	Pos. 13 Name: Plain washer Quantity: 5 Dim. : Ø 10,5 mm 
Pos. 2 Name: Tow ball Quantity: 1 	Pos. 8 Name: Bolt 8,8 B Quantity: 4 Dim. : M12x25mm 	Pos. 14 Name: Spring washer Quantity: 4 Dim. : Ø 12,2 mm 
Pos. 3 Name: Socket plate Quantity: 1 	Pos. 9 Name: Bolt 8,8 B Quantity: 5 Dim. : M10x90mm 	Pos. 15 Name: Spring washer Quantity: 5 Dim. : Ø 10,2 mm 
Pos. 4 Name: Left fish-plate Quantity: 1 	Pos. 10 Name: Body of the automat Quantity: 1 	Pos. 16 Name: Ball cover Quantity: 1 
Pos. 5 Name: Right fish-plate Quantity: 1 	Pos. 11 Name: Nut 8 B Quantity: 5 Dim. : M10 	Pos. 17 Name: Body plug Quantity: 1 

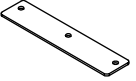

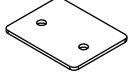
PPUH AUTO-HAK S.J.

Produkcja Zaczepów Kulowych
Henryk & Zbigniew Nejman
76-200 SŁUPSK ul. Słoneczna 16K
tel/fax (059) 8-414-414; 8-414-413
E-mail: office@autohak.com.pl
www.autohak.com.pl

Towing hitch (without electrical set)

Class: **A50-X** Cat. no. **E17A**

Designed for:

Manufacturer: **OPEL**

Model: **OMEGA "B"**

Type: **ESTATE**

produced since 1994 till 2003

Technical data:

D-value: 10,45 kN

maximum trailer weight: **2000 kg**

maximum vertical cup load: **75 kg**

Approval number acc. to regulations EKG/ONZ 55.01: **E20-55R-01 0993**

Foreword

This towbar is designed according to rules of safety traffic regulations. The towing hitch is a safety component and can be install only by qualified personnel. Any alteration or conversion of the towing hitch is prohibited and would lead to cancellation of design certification. Remove insulating compound and underseal from vehicle (if present) in the area of the matting surfaces of the towing hitch.

The vehicle manufacturer's specifications regarding trailer load and max. vertical cup load are decisive for driving whereat values for the towing hitch cannot be exceeded.

D-value formula:

$$\frac{\text{Max trailer weight [kg]} \times \text{Max vehicle weight [kg]}}{\text{Max trailer weight [kg]} + \text{Max vehicle weight [kg]}} \times \frac{9,81}{1000} = D \text{ [kN]}$$

FITTING INSTRUCTION

Clamp mark in acc. with		Cables joining
ISO	PN	
1	L	Left directional lights
2	+	Rear fog lights
3	31	Ground
4	R	Right directional lights
5	58R	Right side parking lights
6	54	Stoplights
7	58L	Left side parking lights

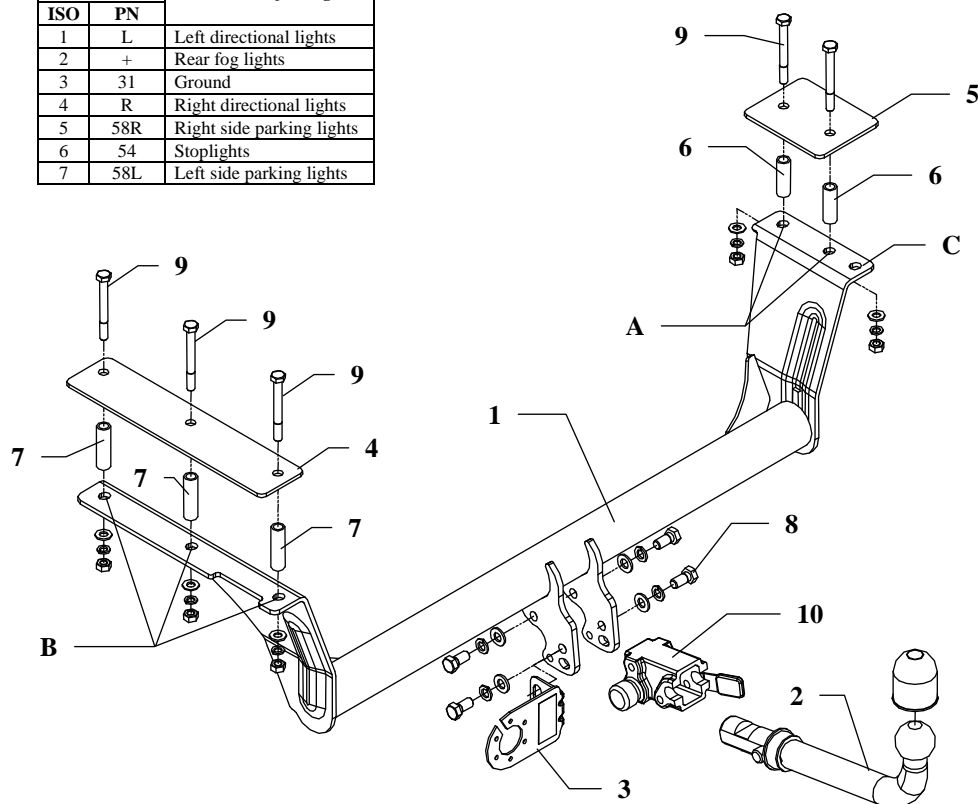

This towbar is designed to assembly in following cars:
OPEL OMEGA "B" ESTATE, produced since 1994 till 2003, catalogue no. **E17A** and is prepared to tow trailers max total weight **2000kg** and max vertical load **75kg**.

From manufacturer

Thank you for buying our product. Their reliability has been confirmed in many tests. Reliability of towbar depends also on correct assembly and right operation. For this reasons we kindly ask to read carefully this instruction and apply to hints.

The towbar should be install in points described by a car producer.

The instruction of the assembly

- To install towbar you have to twist off handle (patch) fuel tank bolt.
- Take off muffler from rubber handles and get it lower. Disassemble heat cover over muffler.
- Inside the trunk (in factory marked points) make two (right side, pos. A) and three (left side, pos. B) holes with drill $\varnothing 17,5\text{mm}$.
- In made holes put distance sleeves (pos. 6 and 7). On the right side length $L=50\text{mm}$ and on the left side length $L=60\text{mm}$ (all from the inside).
- Put main bar of towbar (pos. 1) from below and through holes pos. A and B and distance sleeves and washers (from equipment) fix all with bolts $M10 \times 90\text{mm}$ (pos. 9) from equipment. (from the inside)
- Through hole (pos. C) fix early dismantled fuel tank handle bolt. (see point 1 of this instruction).
- Fix body of the automat (pos. 10) and the socket plate (pos. 3) using bolts $M12 \times 25\text{mm}$ (pos. 8) from accessories. Place tow-ball (pos. 2) according to supplied instruction.
- Fix heat cover and hang on the a muffler.
- Tighten all bolts according to the torque shown in the table.
- Connect electric wires of 7-poles socket according to the instruction of the car. (Recommend to make at authorized service station).
- Complete paint layer damaged during installation.

Torque settings for nuts and bolts (8,8):	
M 8 - 25 Nm	M 10 - 55 Nm
M 12 - 85 Nm	M 14 - 135 Nm

NOTE

After install the towbar you should get adequate note in registration book (at authorised service station).The car should be equipped with:

- Indicators
- Tow mirrors

After 1000km of exploitation check all bolts and nuts. The ball of towbar must be always kept clear and conserve with a grease.