

FITTING INSTRUCTION

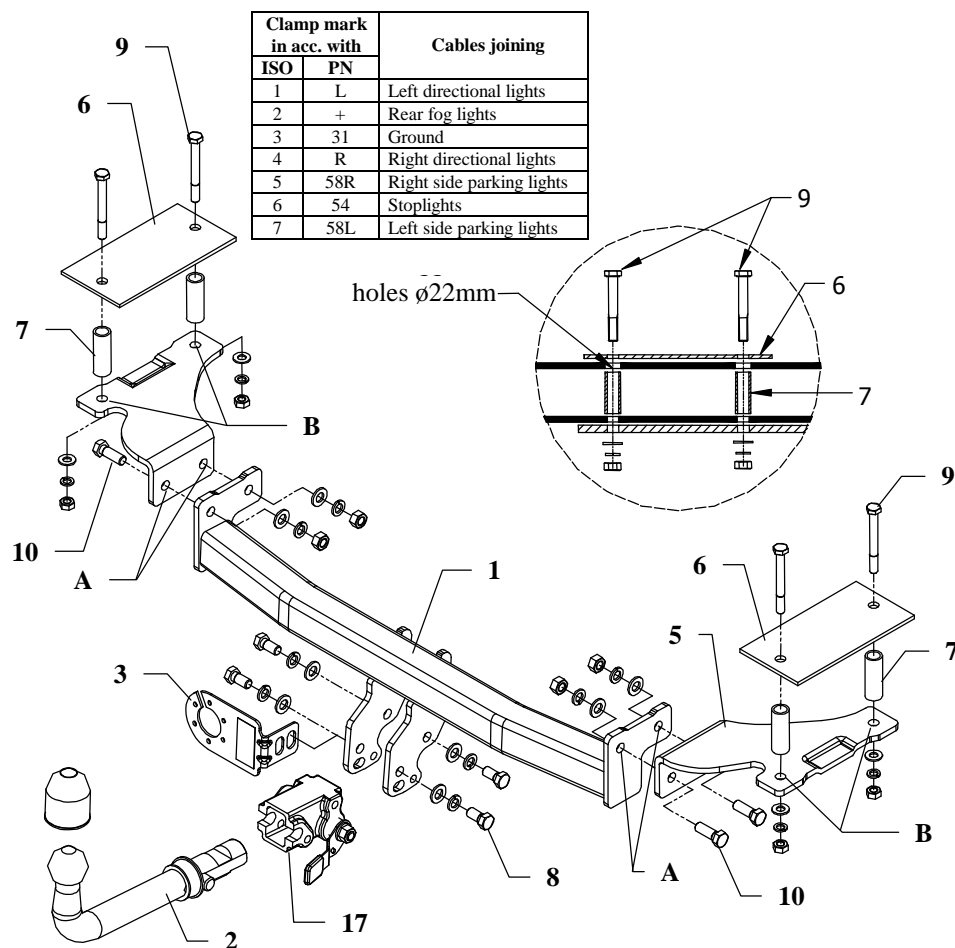

This towbar is designed to assembly in following car:
OPEL COMBO „B”, produced since 09.1995 till 08.2001, catalogue number **E20A** and is prepared to tow trailers max total weight **1200 kg** and max vertical load **50 kg**.

From manufacturer

Thank you for buying our product. Their reliability has been confirmed in many tests. Reliability of towbar depends also on correct assembly and right operation. For this reasons we kindly ask to read carefully this instruction and apply to hints.

The towbar should be install in points described by a car producer.

The instruction of the assembly

1. To install this towbar disassemble the spare wheel and take out the floor finish.
2. On the left and right side of the trunk find per three original marked points, next drill per two outmost holes on each side using bit $\varnothing 11\text{mm}$ (through chassis members also).
3. Using bit $\varnothing 22\text{mm}$ enlarge holes only from trunk side (in upper part of chassis members).
4. To made holes (pos. B) put distance sleeves (pos. 7) and put fish-plates (pos. 6) and insert bolts M10x90mm (pos. 9).
5. Underneath the car on protruding bolts put side brackets (pos. 4 and 5) and fix loosely.
6. Between installed brackets put main bar of the towbar (pos. 1) and fix by holes (pos. A) using bolts M12x35mm (pos. 10) from towbar accessories.
7. Fix body of the automat (pos. 17) and the socket plate (pos. 3) using bolts M12x25mm (pos. 8) from accessories. Place tow-ball (pos. 2) according to supplied instruction.
8. Fix tight all bolts according to the torque shown in the table.
9. Connect electric wires of 7-poles socket according to the instruction of the car. (Recommend to make at authorized service station)
10. Complete paint layer damaged during installation.

Torque settings for nuts and bolts (8,8):	
M 8 - 25 Nm	M 10 - 55 Nm
M 12 - 85 Nm	M 14 - 135 Nm

NOTE

After install the towbar you should get adequate note in registration book (at authorised service station).The car should be equipped with:

- Indicators
- Tow mirrors

After 1000km of exploitation check all bolts and nuts. The ball of towbar must be always kept clear and conserve with a grease.

Towbar accessories:

Pos. 1 Name: Main bar Quantity: 1	Pos. 5 Name: Right bracket Quantity: 1	Pos. 10 Name: Bolt 8,8 B Quantity: 4 Dim.: M12x35	Pos. 15 Name: Spring washer Quantity: 8 Dim.: ϕ 12,2 mm
Pos. 2 Name: Tow ball Quantity: 1	Pos. 6 Name: Fish-plate Quantity: 2	Pos. 11 Name: Nut 8 B Quantity: 4 Dim.: M12	Pos. 16 Name: Spring washer Quantity: 4 Dim.: ϕ 10,2 mm
Pos. 3 Name: Socket plate Quantity: 1	Pos. 7 Name: Distance sleeve Quantity: 4 Dim.: ϕ 21.3x2,65mm L=60mm	Pos. 12 Name: Nut 8 B Quantity: 4 Dim.: M10	Pos. 17 Name: Body of the automat Quantity: 1
Pos. 4 Name: Left bracket Quantity: 1	Pos. 8 Name: Bolt 8,8 B Quantity: 4 Dim.: M12x25mm	Pos. 13 Name: Plain washer Quantity: 8 Dim.: ϕ 13 mm	Pos. 18 Name: Body plug Quantity: 1
	Pos. 9 Name: Bolt 8,8 B Quantity: 4 Dim.: M10x90mm	Pos. 14 Name: Plain washer Quantity: 4 Dim.: ϕ 10,5 mm	Pos. 19 Name: Ball cover Quantity: 1



PPUH AUTO-HAK S.J.

Produkcja Zaczepów Kulowych
Henryk & Zbigniew Nejman
76-200 SŁUPSK ul. Słoneczna 16K
tel/fax (059) 8-414-414; 8-414-413
e-mail: office@autohak.com.pl
www.autohak.com.pl

Towing hitch (without electrical set)

Class: **A50-X** Cat. no. **E20A**

Designed for:

Manufacturer: **OPEL**

Model: **COMBO**

Type: **delivery truck**

produced since 09.1995 till 08.2001

Technical data:

D-value: 7,49 kN

maximum trailer weight: **1200 kg**

maximum vertical cup load: **50 kg**

Approval number according to Directive 94/20/EC: **e20*94/20*0765*00**

Foreword

This towbar is designed according to rules of safety traffic regulations. The towing hitch is a safety component and can be install only by qualified personnel. Any alteration or conversion of the towing hitch is prohibited and would lead to cancellation of design certification. Remove insulating compound and underseal from vehicle (if present) in the area of the matting surfaces of the towing hitch.

The vehicle manufacturer's specifications regarding trailer load and max. vertical cup load are decisive for driving, and values for the towing hitch cannot be exceeded.

D-value formula:

$$\frac{\text{Max trailer weight [kg]} \times \text{Max vehicle weight [kg]}}{\text{Max trailer weight [kg]} + \text{Max vehicle weight [kg]}} \times \frac{9,81}{1000} = D \text{ [kN]}$$