

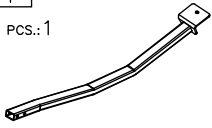













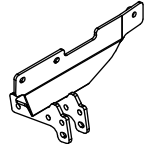

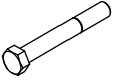

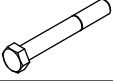

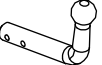

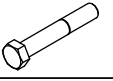
Towing hitch accessories:

Pos. 1 Main bar PCS.: 1 	Pos. 5 Socket plate PCS.: 1 	Pos. 11 Washer ø58xø12x3mm PCS.: 1 	Pos. 18 Nut 8 B M12 PCS.: 2 
	Pos. 6 Distance sleeve ø17.2x2.35mm L=39mm PCS.: 1 	Pos. 12 Washer ø35xø12x3mm PCS.: 5 	Pos. 19 Nut 8 B M10 PCS.: 8 
Pos. 2 Main plate PCS.: 1 	Pos. 7 Distance sleeve ø17.2x2.35mm L=16mm PCS.: 1 	Pos. 13 Bolt 8,8 B M12x90mm PCS.: 2 	Pos. 20 Plain washer ø12mm PCS.: 2 
	Pos. 8 Distance sleeve ø17.2x2.35mm L=12mm PCS.: 1 	Pos. 14 Bolt 8,8 B M10x90mm PCS.: 2 	Pos. 21 Plain washer ø10mm PCS.: 8 
Pos. 3 Tow ball PCS.: 1 	Pos. 9 Right jib PCS.: 1 	Pos. 15 Bolt 8,8 B M10x80mm PCS.: 1 	Pos. 22 Spring washer ø12mm PCS.: 2 
Pos. 4 Coverplate PCS.: 2 	Pos. 10 Left jib PCS.: 1 	Pos. 16 Bolt 8,8 B M10x45mm PCS.: 2 	Pos. 23 Spring washer ø10mm PCS.: 8 
		Pos. 17 Bolt 8,8 B M10x30mm PCS.: 3 	Pos. 24 Ball cover PCS.: 1 



PPUH AUTO-HAK Sp.J.

Produkcja Zaczepów Kulowych
Henryk & Zbigniew Nejman
76-200 SŁUPSK ul. Słoneczna 16K
tel/fax (059) 8-414-414; 8-414-413
E-mail: office@autohak.com.pl
www.autohak.com.pl

Towing hitch (without electrical set)

Class: **A50-X** Cat. no. **R03**

Designed for:

Manufacturer: **FIAT**

Model: **TIPO**

Type: **3/5 doors**

produced since 1988 till 1995

Technical data:

D-value: 6,85 kN

maximum trailer weight: **1200 kg**

maximum vertical cup mass: **75 kg**

Approval number acc. to regulations EKG/ONZ 55.01: E20-55R-01 0970

Foreword

This towing hitch is designed according to rules of safety traffic regulations. The towing hitch is a safety component and can be install only by qualified personnel. Any alteration or conversion of the towing hitch is prohibited and would lead to cancellation of design certification. Remove insulating compound and underseal from vehicle (if present) in the area of the matting surfaces of the towing hitch. The vehicle manufacturer's specifications regarding trailer mass and max. vertical cup mass are decisive for driving whereat values for the towing hitch cannot be exceeded.

D-value formula:

$$\frac{\text{Max trailer weight [kg]} \times \text{Max vehicle weight [kg]}}{\text{Max trailer weight [kg]} + \text{Max vehicle weight [kg]}} \times \frac{9,81}{1000} = D \text{ [kN]}$$

FITTING INSTRUCTION

Clamp mark in acc. with		Cables joining
ISO	PN	
1	L	Left directional lights
2	+	Rear fog lights
3	31	Ground
4	R	Right directional lights
5	58R	Right side parking lights
6	54	Stoptlights
7	58L	Left side parking lights

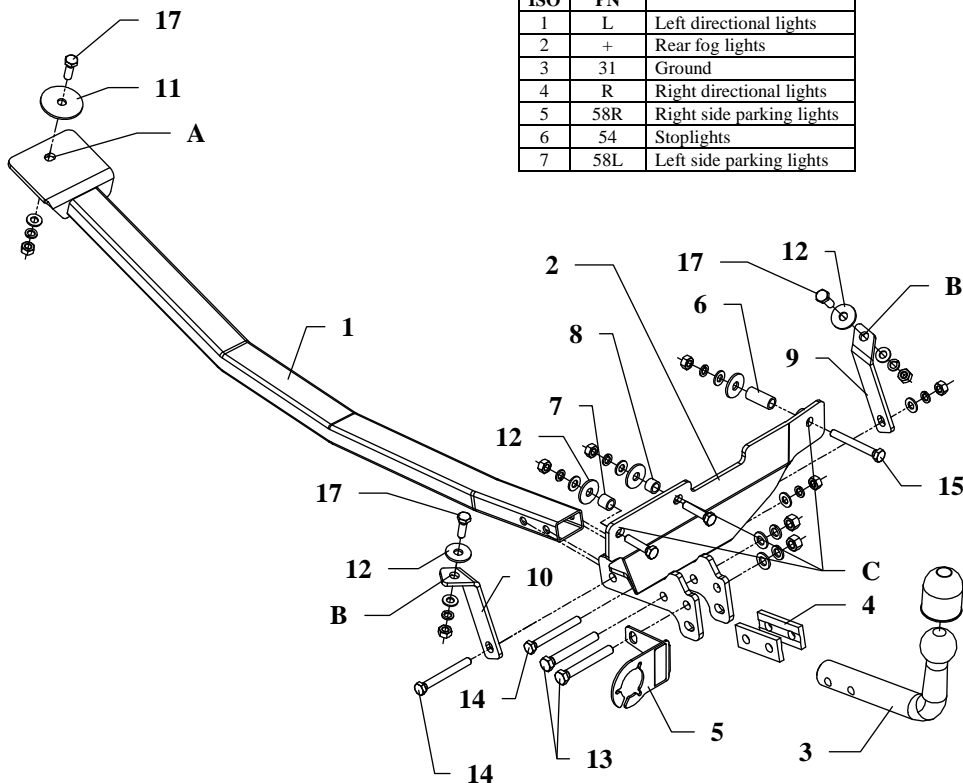

This towing hitch is designed to assembly in following cars:
FIAT TIPO, 3/5 doors, produced since 1988 till 1995, catalogue no. **R03**
 and is prepared to tow trailers max total weight up to **1200 kg** and max
 vertical mass **75 kg**.

From manufacturer

Thank you for buying our product. Their reliability has been confirmed in many tests. Reliability of towing hitch depends also on correct assembly and right operation. For this reasons we kindly ask to read carefully this instruction and apply to hints.

The towing hitch should be install in points described by a car producer.

The instruction of the assembly

1. Unscrew the bumper and take out the spare wheel. The rear seat must be placed. Take out the anti-noise mat.
2. Fix the elements (pos. 1, 2, 9 and 10) with bolts M10x90mm (pos. 14) and M12x90mm (pos. 13). With one of bolts M12x90mm (pos. 13) fix also tow-ball (pos. 3) with coverplates (pos. 4) and socket plate (pos. 5).
3. For this way prepared elements, apply to the car in its symmetrical axis. The main plate (pos. 2) must be adhered to the rear plate, and the main bar (pos. 1) with jibs (pos. 9 and 10) to the chassis.
4. Mark the holes A, B and C. Drill to $\varnothing 10,5\text{mm}$. The hole C is placed under the rear seat.
5. Drill trough to $\varnothing 17\text{ mm}$ the holes C in the rear plate of the car, from the boot, and then put the appropriate distance sleeves (pos. 6, 7 and 8) – see the drawing.
6. Fix the towing hitch in the drilled places. Use the washers and bolts M10 from the accessories.
7. Mount the bumper to the car.
8. Tighten all bolts according to the torque shown in the table.
9. Connect electric wires of 7-poles socket according to the instruction of the car. (Recommend to make at authorized service station).
10. Complete paint layer damaged during installation.

Torque settings for nuts and bolts (8,8):

M6 - 11 Nm	M8 - 25 Nm	M10 - 50 Nm
M12 - 87 Nm	M14 - 138 Nm	M16 - 210 Nm

NOTE

After install the towing hitch you should get adequate note in registration book (at authorised service station). The car should be equipped with:

- Indicators
- Tow mirrors

After 1000km of exploitation check all bolts and nuts. The ball of towing hitch must be always kept clear and conserve with a grease.