

## FITTING INSTRUCTION

Clamp mark in acc. with		Cables joining
ISO	PN	
1	L	Left directional lights
2	+	Rear fog lights
3	31	Ground
4	R	Right directional lights
5	58R	Right side parking lights
6	54	Stoplights
7	58L	Left side parking lights

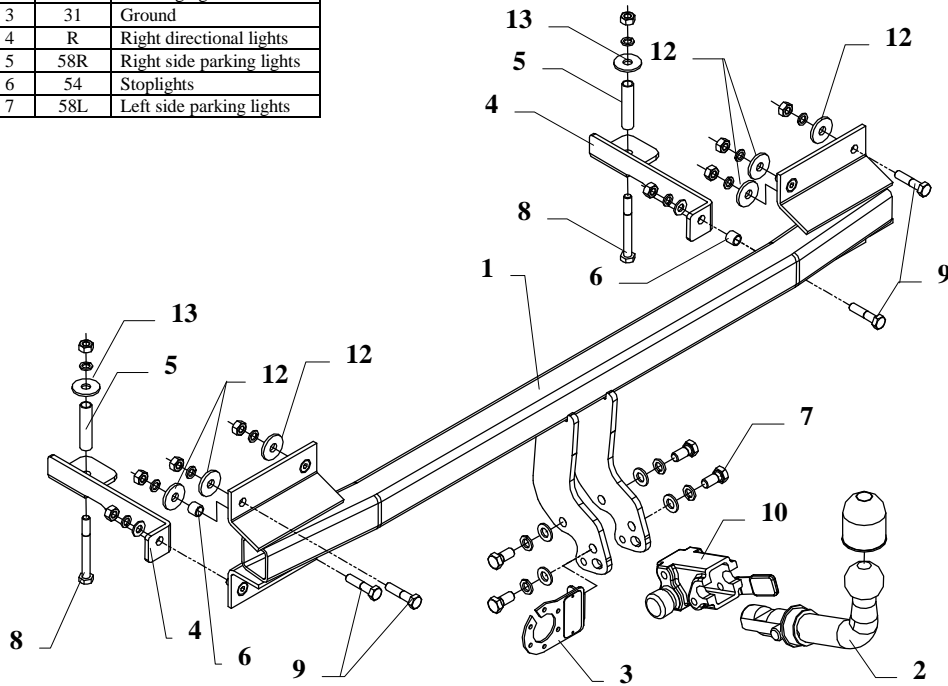

This towing hitch is designed to assembly in following car: **KIA SEPHIA 4/5 door**, produced since 01.1993 till 1998, catalogue no. **T44A** and is prepared to tow trailers max total weight **1450 kg** and max vertical load **50 kg**.

### *From manufacturer*

Thank you for buying our product. Their reliability has been confirmed in many tests. Reliability of towing hitch depends also on correct assembly and right exploit. For this reasons we kindly ask to read carefully this instruction and apply to hints.

*The towing hitch should be install in points described by a car producer.*

## The instruction of the assembly

1. Disassemble the rear bumper.
2. From left and right bumpers fastening twist off original screws and put screws M10x45mm (pos. 9).
3. On rear panel are 8 original holes (4 per each side)  $\varnothing 8$ mm, drill it using bit  $\varnothing 10$ mm.
4. Put main bar of towing hitch (pos. 1) on screws (pos. 9) protruding from the bumper. All unit (main bar and bumper) put to rear panel and fix by nuts (loosely), remember about big washers (pos. 12) and distance sleeve (pos. 6) on the left side. Do not twist on nuts in places where will be brackets pos. 4, see drawing.
5. From below the car put suitable brackets (pos. 4) to chassis members. Through brackets hole drill holes  $\varnothing 10,5$ mm to the trunk. From trunk side drill it again using bit  $\varnothing 15$ mm (only in upper side of chassis members). From trunk side to drilled holes put distance sleeves (pos. 5) and fix it according to the drawing. Fix brackets to main bar of the towing hitch, remember about sleeve (pos. 6) on the right side.
6. Fix body of the automat (pos. 10) and the socket plate (pos. 3) using bolts M12x25mm (pos. 7) from accessories. Place tow-ball (pos. 2) according to supplied instruction.
7. Tighten all bolts according to the torque shown in the table.
8. Connect electric wires of 7-pole socket according to the instruction of the car. (Recommend to make at authorized service station)
9. Complete paint layer damaged during installation.

Torque settings for nuts and bolts (8,8):

<b>M8</b>	25 Nm	<b>M10</b>	55 Nm
<b>M12</b>	85 Nm	<b>M14</b>	135 Nm











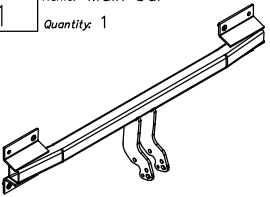

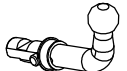
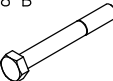

### NOTE

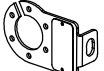
After install the towing hitch you should get adequate note in registration book (at authorised service station). The car should be equipped with:

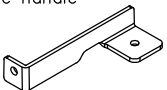
- Indicators
- Tow mirrors

After 1000km check all bolts and nuts. The ball of towing hitch must be always kept clear and conserve with a grease.

## Towing hitch accessories:

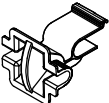
Pos. 1 Name: Main bar Quantity: 1 	Pos. 6 Name: Distance sleeve II Quantity: 2 Dim.: $\varnothing 15 \times \varnothing 12 \text{mm}$ L=13mm 	Pos. 13 Name: Washer Quantity: 2 Dim.: $\varnothing 35 \times \varnothing 12 \times 3 \text{mm}$ 
	Poz. 7 Name: Bolt 8.8 B M12x25mm SZTUK: 4 	Pos. 14 Name: Plain washer Quantity: 4 Dim.: $\varnothing 13 \text{ mm}$ 
Pos. 2 Name: Tow ball Quantity: 1 	Pos. 8 Name: Bolt 8.8 B Quantity: 2 Dim.: M10x90mm 	Pos. 15 Name: Plain washer Quantity: 2 Dim.: $\varnothing 10,5 \text{ mm}$ 
Pos. 3 Name: Socket plate Quantity: 1 	Pos. 9 Name: Bolt 8.8 B Quantity: 4 Dim.: M10x45mm 	Pos. 16 Name: Spring washer Quantity: 4 Dim.: $\varnothing 12,2 \text{ mm}$ 
Pos. 4 Name: Side handle Quantity: 2 	Poz. 10 Name: Body of the automat SZTUK: 1 	Pos. 17 Name: Spring washer Quantity: 10 Dim.: $\varnothing 10,2 \text{ mm}$ 
Pos. 5 Name: Distance sleeve I Quantity: 2 Dim.: $\varnothing 15 \times \varnothing 12 \text{mm}$ L=65mm 	Pos. 11 Name: Nut 8 B Quantity: 10 Dim.: M10 	Pos. 18 Name: Ball cover Quantity: 1 
	Pos. 12 Name: Washer Quantity: 6 Dim.: $\varnothing 35 \times \varnothing 12 \times 4 \text{mm}$ 	Poz. 19 Name: Body plug SZTUK: 1 



## PPUH AUTO-HAK S.J.

Produkcja Zaczepów Kulowych  
Henryk & Zbigniew Nejman  
76-200 SŁUPSK ul. Słoneczna 16K  
tel/fax (059) 8-414-414; 8-414-413  
E-mail: office@autohak.com.pl  
www. autohak.com.pl

### Towing hitch (without electrical set)

Class: **A50-X** Cat. no. **T44A**

Designed for:

Manufacturer: **KIA**

Model: **SEPHIA**

Type: **4/5 door**

produced since 01.1993 till 1998

Technical data:

**D-value: 7,38 kN**

maximum trailer weight: **1450 kg**

maximum vertical cup load: **50 kg**

Approval number according to Directive 94/20/EC: **e20\*94/20\*0612\*00**

### Foreword

This towing hitch is design according to rules of safety traffic regulations. The towing hitch is a safety component and must be installed only by qualified personnel. Any alteration or conversion to the towinh hitch is prohibited and would lead to cancellation of design certification. Remove insulating compound and underseal from vehicle (if present) in the area of the matting surfaces of the towing hitch.

The vehicle manufacturer's specifications regarding trailer load and max. vertical cup load are decisive for driving, and values for the towing hitch must not be exceeded.

D-value formula:

$$\frac{\text{Max trailer weight [kg]} \times \text{Max vehicle weight [kg]}}{\text{Max trailer weight [kg]} + \text{Max vehicle weight [kg]}} \times \frac{9,81}{1000} = D \text{ [kN]}$$